

# SMD Power Inductor

## CDB87D48

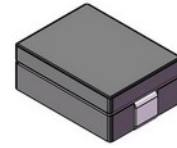

### 特点

- Ferrite core construction
- Magnetically shielded
- L×W×H:12.0×9.0×5.2mm Max.
- Product weight: 2.24g (Ref.)
- Moisture Sensitivity Level: 1

### 环境规格

- Operating temperature range: -40°C~+125°C (including coil's self temperature rise)
- Storage temperature range: -40°C~+125°C

### 包装

- Carrier tape and reel packaging
- 500pcs per reel

### 用途

- Multi-phase and Vcore regulators
- Voltage Regulator Modules (VRMs), such as Server and desktop, Central Processing Unit (CPU), Graphics Processing Unit (GPU), Application Specific Integrated Circuit (ASIC), High power density
- Data networking density
- Graphics cards and battery power systems

### 外形尺寸 - [mm]

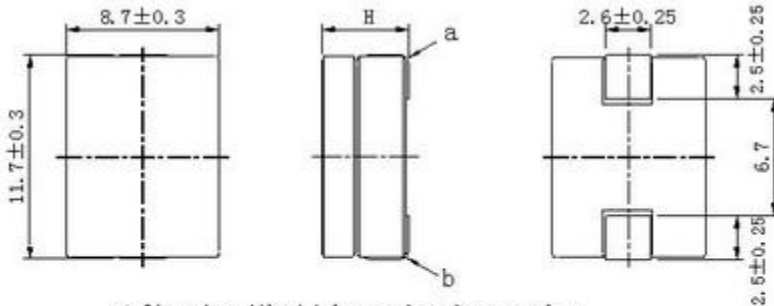

\* Dimension without tolerance is reference value.  
\* The DCR is measured from point "a" to "b".

Dimensions Inductance	H (mm)
0.10μH~0.12μH	5.0 <sup>+0.2</sup> <sub>-0.3</sub>
0.15μH~0.23μH	4.8 <sup>+0.2</sup> <sub>-0.3</sub>

### 推荐焊盘尺寸 - [mm]

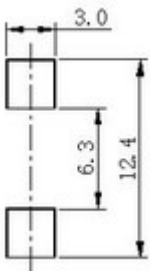

### 接线图 (底面)

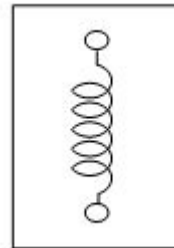

# SMD Power Inductor

## CDB87D48



### 电气特性规格

品名	电感值 [within] ( $\mu$ H) ※1	直流电阻 (20℃) Max. (Typ.) (m $\Omega$ )	饱和电流 (A) Max. (Typ.) ※2		温度上升电流 (A) Max. (Typ.) ※3
			20℃	125℃	
CDB87D48NP-R10MC	0.10 $\pm$ 20%	(0.23)	78.00 (92.00)	63.00 (74.00)	(65.00)
CDB87D48NP-R12MC	0.12 $\pm$ 20%	(0.23)	65.00 (76.00)	51.00 (60.00)	(65.00)
CDB87D48NP-R15MC	0.15 $\pm$ 20%	(0.23)	52.00 (61.00)	41.00 (48.00)	(65.00)
CDB87D48NP-R23MC	0.23 $\pm$ 20%	(0.23)	32.00 (38.00)	25.00 (30.00)	(65.00)

※1 Measuring frequency inductance at 1MHz.

※2 Saturation current: This indicates the value of D.C. current when the inductance becomes 20% lower than its initial value.

※3 Temperature rise current: The value of D.C. current when temperature of coil increased  $\Delta T=40^{\circ}\text{C}$  ( $T_a=20^{\circ}\text{C}$ ).

### 回流焊耐热与推荐温度曲线图

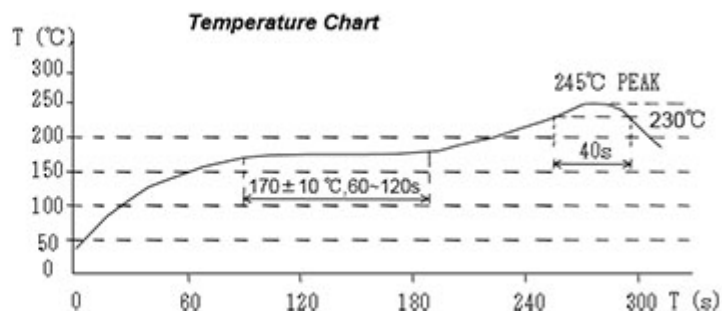
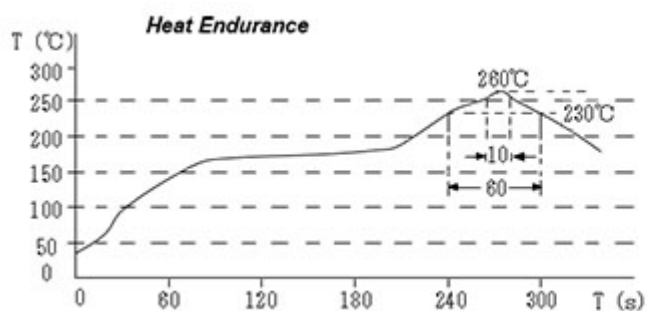

# SMD Power Inductor

## CDB87D48



### 直流饱和电流&温度上升曲线图

— L (20°C) — L (100°C) — L (125°C) —  $\Delta T$

1. CDB87D48NP-R10MC

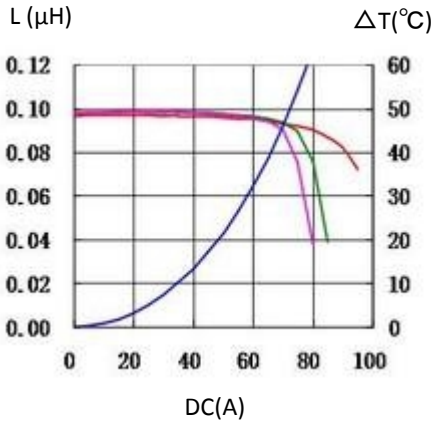

2. CDB87D48NP-R12MC

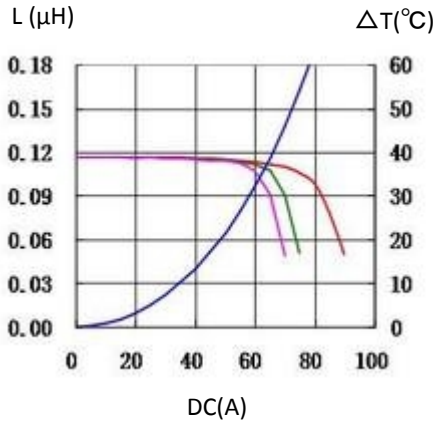

3. CDB87D48NP-R15MC

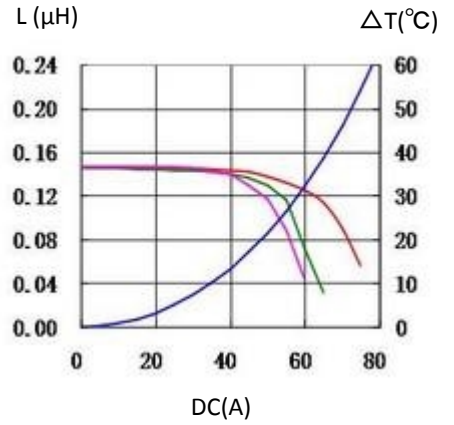

4. CDB87D48NP-R23MC

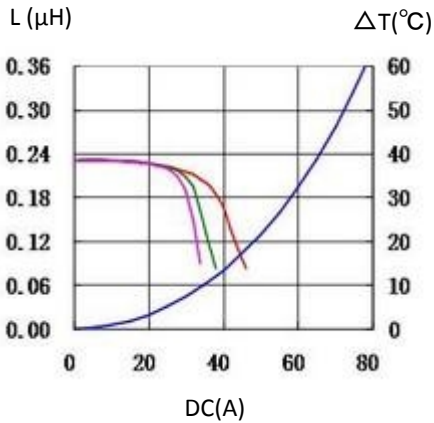

有关销售办事处的信息，请 [点击这里](#)。