

SMD Power Inductor

CDRH6D38/T125



特点

- Ferrite drum core construction
- Magnetically shielded
- L×W×H: 7.0×7.0 ×4.0 mm Max.
- Product weight:0.6g(Ref.)
- Moisture Sensitivity Level: 1
- Qualification to AEC-Q200



环境规格

- Operating Temperature: -40°C to +125°C (including self-heating)
- Storage temperature range: -40°C~+125°C

包装

- Carrier tape and reel packaging

用途

- High temp and high reliability automotive applications

外形尺寸 - [mm]

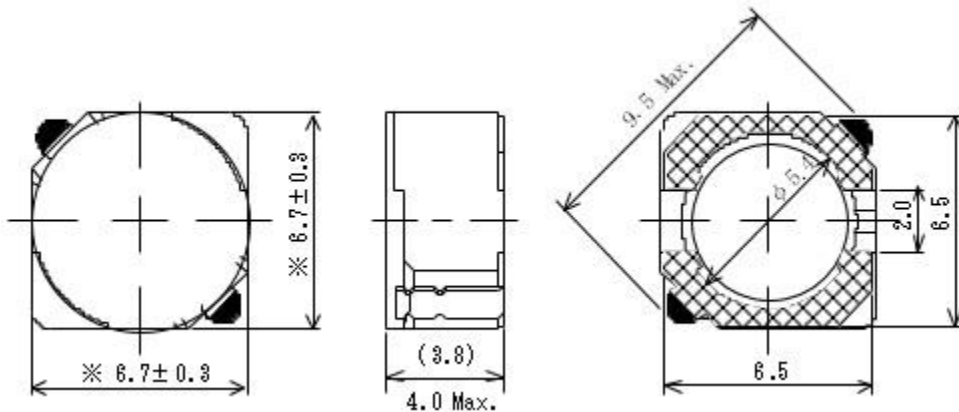

推荐焊盘尺寸 - [mm]

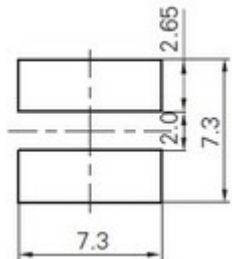

接线图 (底面)

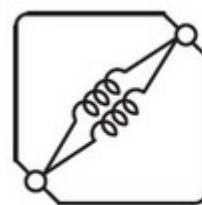

(3.0µH - 15µH)

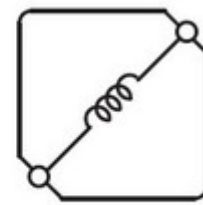

(22µH - 100µH)



电气特性规格

品名	电感值 [within] (μH) ※1	直流电阻 (20℃) Max. (Typ.) (m Ω)	饱和电流 (A) Max. (Typ.) ※2	温度上升电流 (A) Max. (Typ.) ※3
CDRH6D38T125NP-3R0NC	3.00 \pm 30%	22.00 (17.50)	3.90 (4.70)	4.50 (5.50)
CDRH6D38T125NP-3R9NC	3.90 \pm 30%	24.50 (19.60)	3.30 (4.10)	4.00 (4.70)
CDRH6D38T125NP-4R7NC	4.70 \pm 30%	27.50 (22.00)	3.10 (3.70)	3.80 (4.30)
CDRH6D38T125NP-5R6NC	5.60 \pm 30%	30.50 (24.40)	2.85 (3.50)	3.50 (4.10)
CDRH6D38T125NP-6R8NC	6.80 \pm 30%	33.00 (26.40)	2.60 (3.20)	3.30 (4.00)
CDRH6D38T125NP-100PC	10.00 \pm 25%	43.50 (34.80)	2.20 (2.60)	3.00 (3.65)
CDRH6D38T125NP-150PC	15.00 \pm 25%	59.80 (47.80)	1.80 (2.15)	2.20 (2.63)
CDRH6D38T125NP-220PC	22.00 \pm 25%	103.40 (82.70)	1.50 (1.80)	1.65 (2.05)
CDRH6D38T125NP-330PC	33.00 \pm 25%	145 (116)	1.25 (1.42)	1.45 (1.75)
CDRH6D38T125NP-470PC	47.00 \pm 25%	181 (145)	1.00 (1.25)	1.20 (1.41)
CDRH6D38T125NP-680PC	68.00 \pm 25%	250 (200)	0.85 (1.02)	1.00 (1.20)
CDRH6D38T125NP-101PC	100 \pm 25%	372 (298)	0.68 (0.83)	0.85 (1.04)

※1. Inductance measuring condition: at 100kHz.

※2. Saturation current: The value of D.C. current when the inductance decreases to 65% of it's nominal value.

※3. Temperature rise current: The value of D.C. current when the temperature rise is $\Delta t=40^\circ\text{C}$ ($T_a=20^\circ\text{C}$).

回流焊耐热与推荐温度曲线图

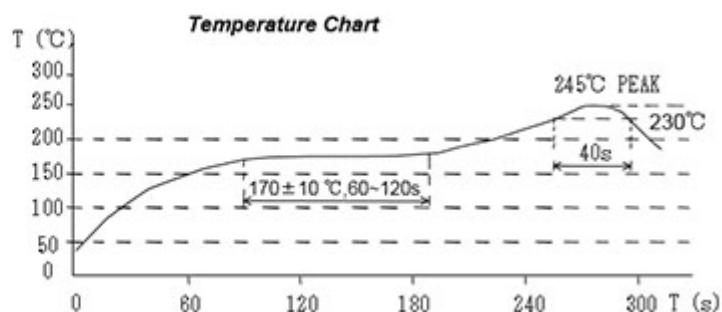
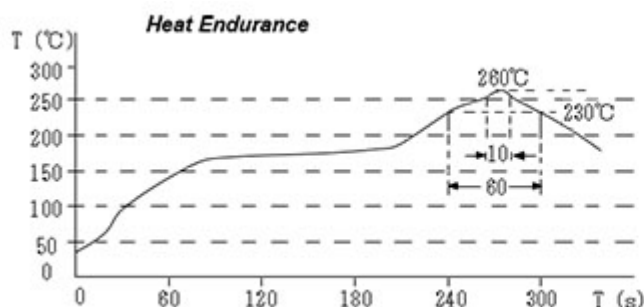

SMD Power Inductor

CDRH6D38/T125



直流饱和电流&温度上升曲线图

— L (20°C) — L (125°C) — ΔT

1. CDRH6D38T125NP-3R0NC

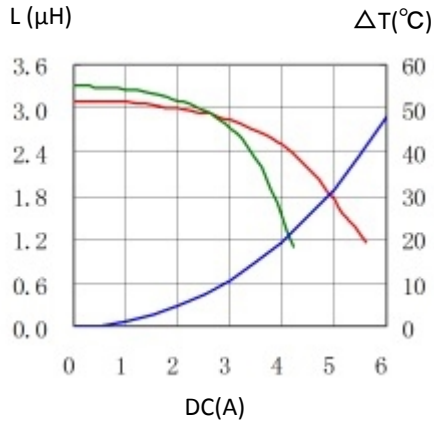

2. CDRH6D38T125NP-3R9NC

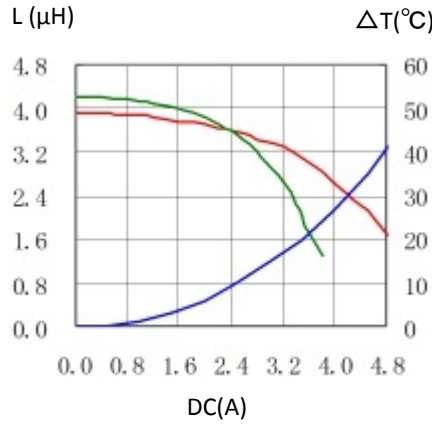

3. CDRH6D38T125NP-4R7NC

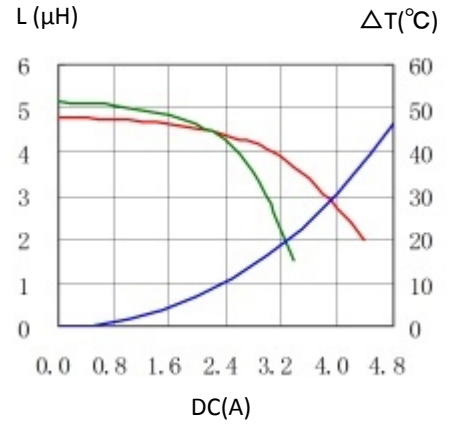

4. CDRH6D38T125NP-5R6NC

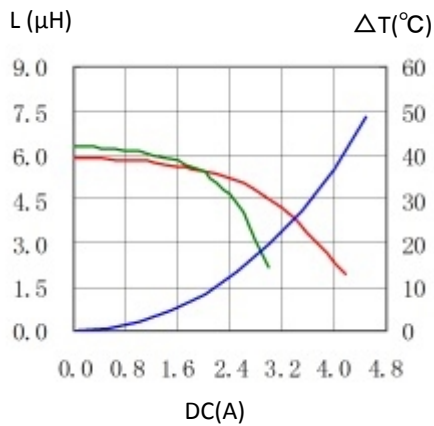

5. CDRH6D38T125NP-6R8NC

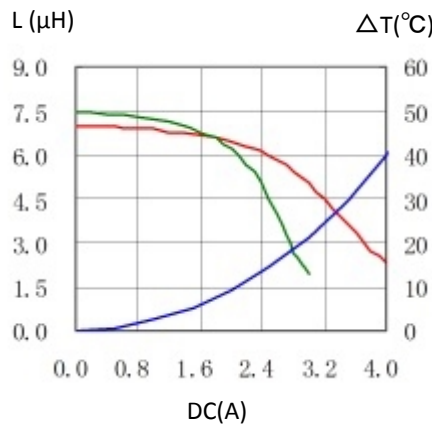

6. CDRH6D38T125NP-100PC

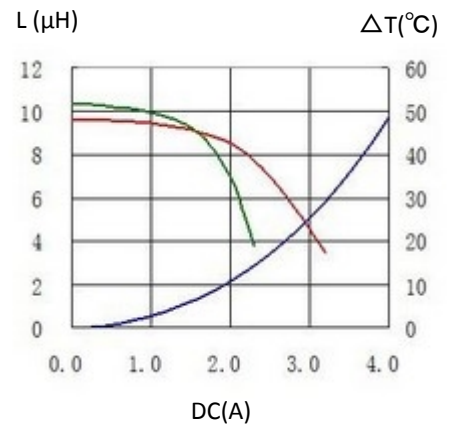

7. CDRH6D38T125NP-150PC

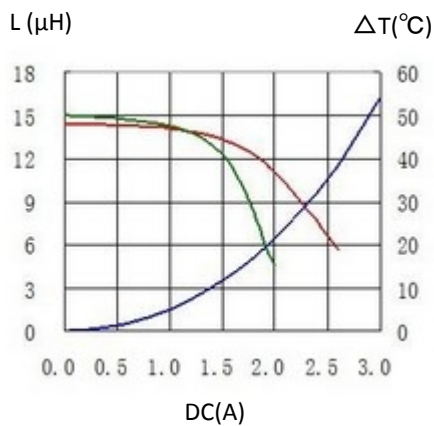

8. CDRH6D38T125NP-220PC

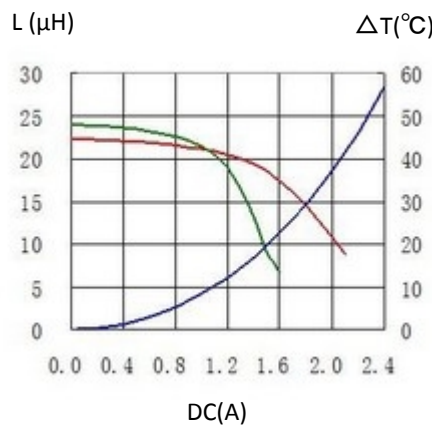

9. CDRH6D38T125NP-330PC

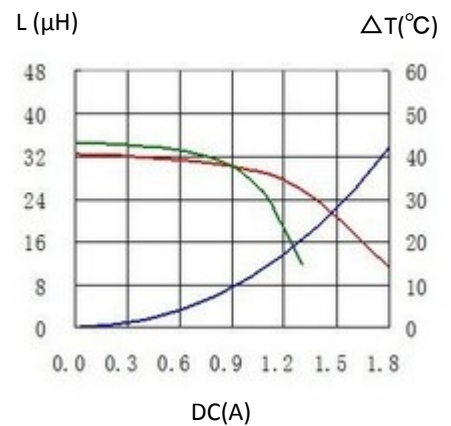

注：记载内容如有变更，恕不另行通知。订货时请联系您最近的销售办事处以获取最新产品信息。

SMD Power Inductor

CDRH6D38/T125



10. CDRH6D38T125NP-470PC

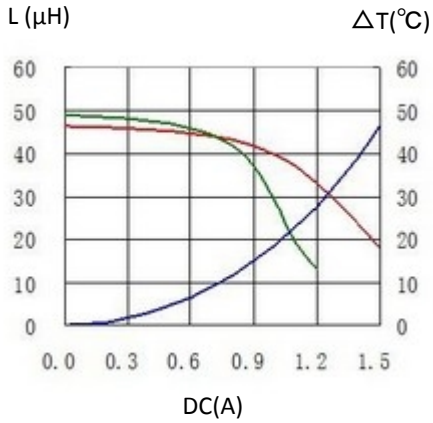

11. CDRH6D38T125NP-680PC

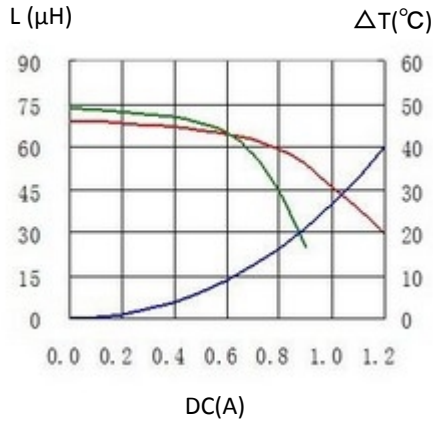

12. CDRH6D38T125NP-101PC

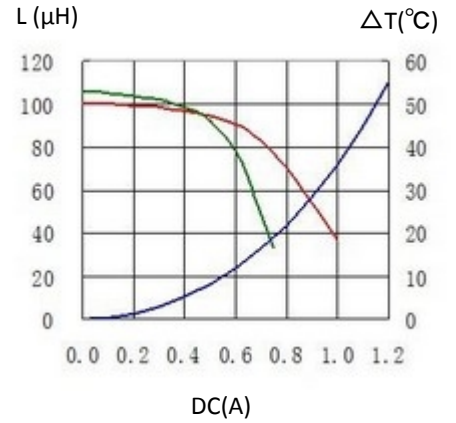

有关销售办事处的信息，请 [点击这里](#)。